

# TECHNICAL DATA SHEET



## XHE-100-2 Electronic Handle Applicator Machine



### Description

The XHE-100-2 Electronic Handle applicator Machine represents the top of the range of our series of handle applicator machine for adhesive.

It is one of the most powerful machines and speeds present in the market at a maximum speed of 100 packs/min on the single track and 200 packs/min on the double track. The machine is equipped with three changes in speed with a sensor series in ingress into uscita.

The design of the arm of the application of the handle is patented.

### TECHNICAL DATA

DATA NAME	DATA VALUE	UNIT OF MEASURE
Machine Model	XHE-100-2	
Max Production	72.000	bottles/hour
Speed for lanes	100	packs/min
Number of lanes	2	
Electric power	6	kWh
Air pressure	air not required	bar
Air flow	air not required	NI/s
Power supply	380-415	V
Electrical phases	3PH-N-PE	
Frequency	50	Hz

DECIMO SRL

via Volla, 28  
03030 PIEDIMONTE SAN GERMANO (FR)  
ITALY

Tel: +39 (0776) 729038  
Email: info@decimosrl.it  
website: www.decimosrl.it

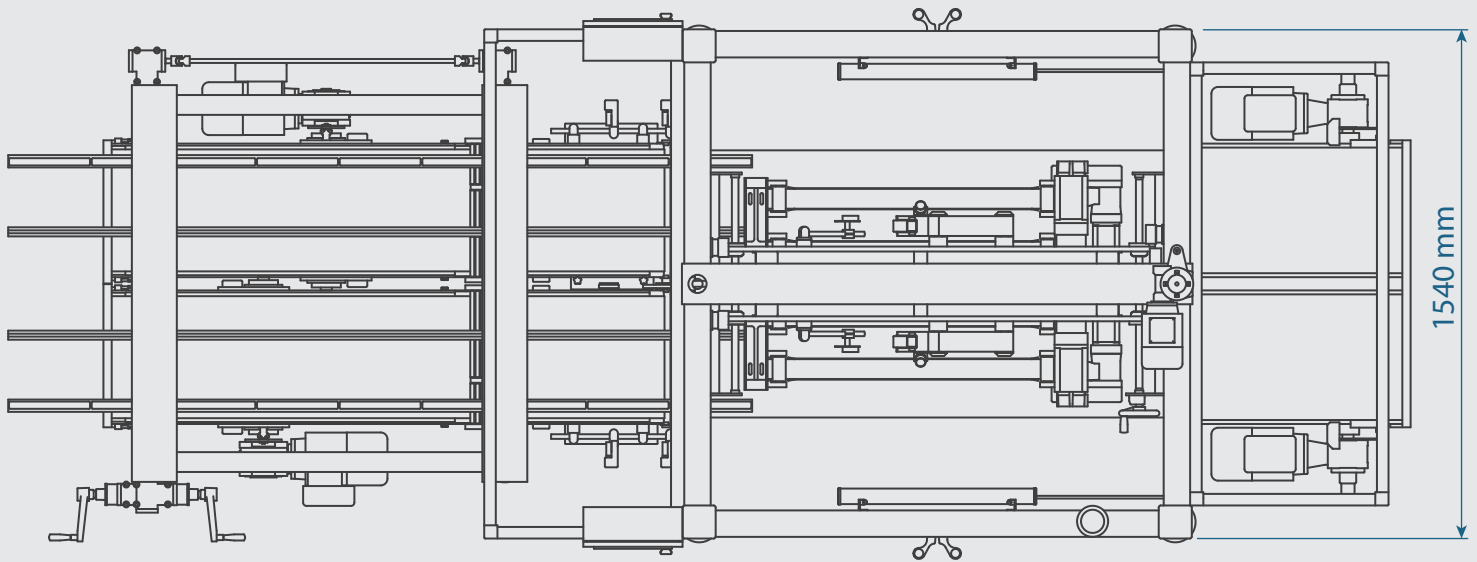
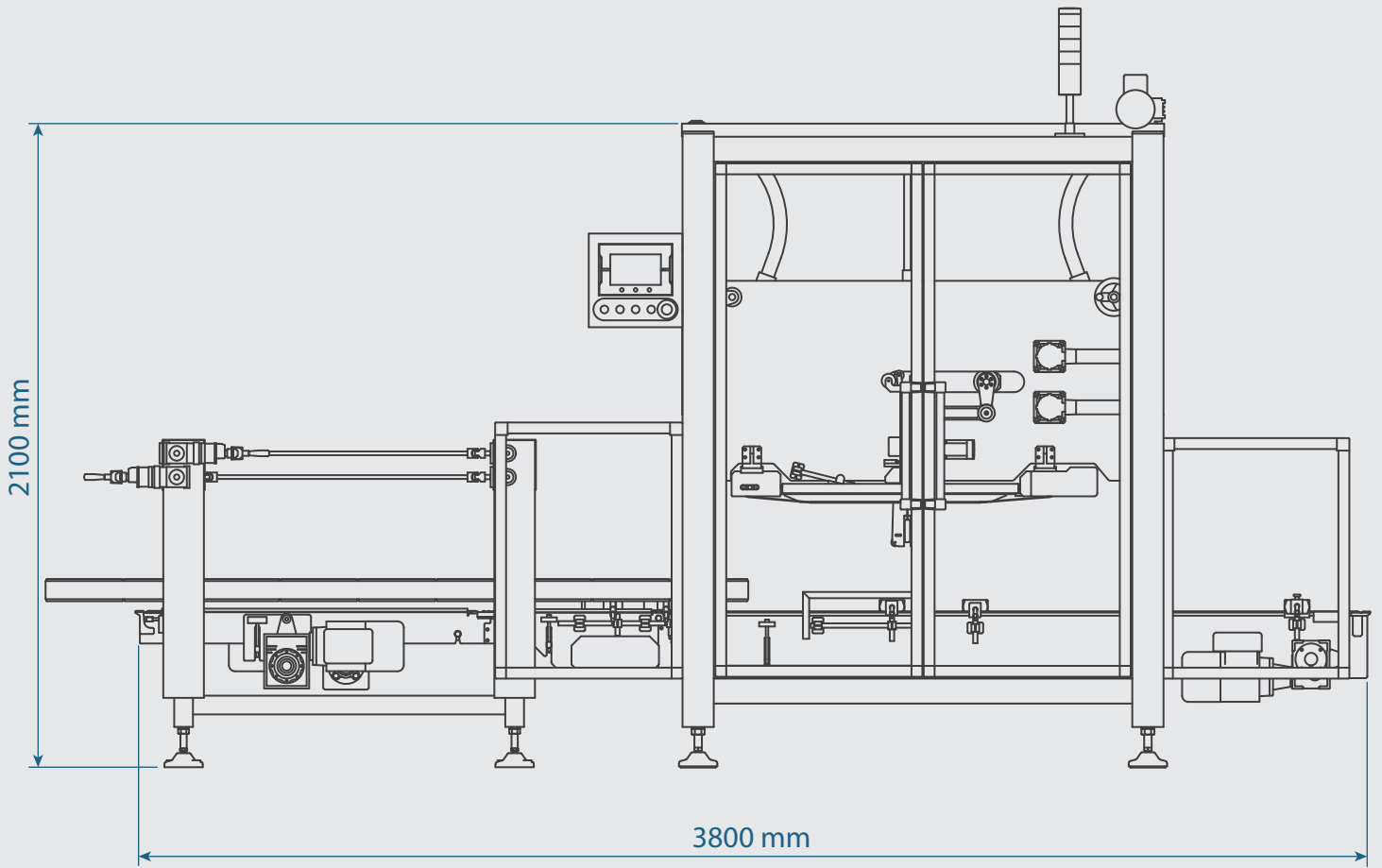

DATA	DATE	09/01/2023
DISEGNATO	DRAWN BY	AF
VISTO	SEEN BY	LC
APPROVATO	APPROVED BY	AB

**DECIMO**  
 Via Volla 28 Sub 2  
 Piedimonte San Germano (FR) 03030

**XHE-100-2**

A B C D E F